

Modulating linear actuators for adjusting air dampers and slide valves in ventilation and air conditioning systems in buildings

- For air dampers up to approx. 3 m<sup>2</sup>
- Actuating force 450 N
- Nominal voltage AC/DC 24 V
- Control: modulating DC 0 ... 10 V, position feedback DC 2 ... 10 V
- Length of stroke  
100 or 200 mm, fixed

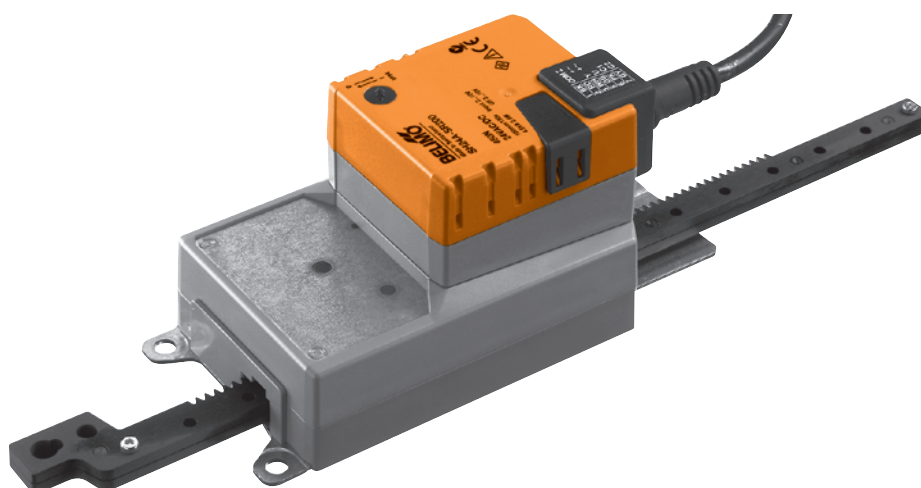

## Overview of types

| Type        | Stroke        | Operating range              | Weight  |
|-------------|---------------|------------------------------|---------|
| SH24A-SR100 | 100 mm, fixed | DC 2 ... 10 V = 0 ... 100 mm | 1.08 kg |
| SH24A-SR200 | 200 mm, fixed | DC 2 ... 10 V = 0 ... 200 mm | 1.15 kg |

## Technical data

|                            |   |   |
|----------------------------|---|---|
| <b>Electrical data</b>     | Nominal voltage                         | AC 24 V, 50/60 Hz<br>DC 24 V  |
|                            | Power supply range                      | AC/DC 19.2 ... 28.8 V   |
|                            | Power consumption                       | In operation 2 W @ nominal force<br>At rest 0.4 W<br>For wire sizing 4 VA   |
|                            | Connection                              | Cable 1 m, 3 x 0.75 mm <sup>2</sup>   |
| <b>Functional data</b>     | Actuating force                         | 450 N @ nominal voltage   |
|                            | Control signal Y                        | DC 0 ... 10 V, typical input impedance 100 kΩ   |
|                            | Operating range                         | See «Overview of types»   |
|                            | Position feedback (Measuring voltage U) | DC 2 ... 10 V, max. 1 mA  |
|                            | Position accuracy                       | ±5%   |
|                            | Stroke                                  | See «Overview of types»   |
|                            | Direction of stroke at Y = 0 V          | Reversible with switch 1↑ resp. 0↓  |
|                            | Running time                            | 150 s / 100 mm  |
| Sound power level          | <50 dB (A)                              |   |
| <b>Safety</b>              | Protection class                        | III Safety extra-low voltage / UL Class 2 Supply  |
|                            | Degree of protection                    | IP54 in any mounting position<br>NEMA 2, UL Enclosure Type 2  |
|                            | EMC                                     | CE according to 2004/108/EC   |
|                            | Certification                           | cULus according to UL 60730-1A and UL 60730-2-14 and CAN/CSA E60730-1:02<br>Certified to IEC/EN 60730-1 and IEC/EN 60730-2-14 |
| <b>Dimensions / Weight</b> | Mode of operation                       | Type 1  |
|                            | Rated impulse voltage                   | Supply 0.8 kV<br>Control 0.8 kV   |
|                            | Control pollution degree                | 3   |
|                            | Ambient temperature range               | -30 ... +50 °C  |
|                            | Non-operating temperature               | -40 ... +80 °C  |
|                            | Ambient humidity range                  | 95% r.H., non-condensating  |
|                            | Maintenance                             | Maintenance-free  |
|                            | Dimensions                              | See «Dimensions» on page 3  |
|                            | Weight                                  | See «Overview of types»   |

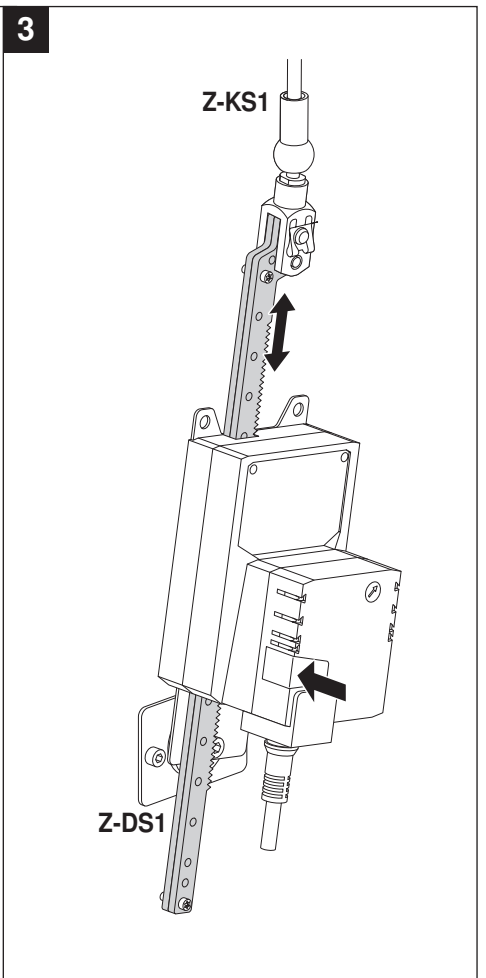
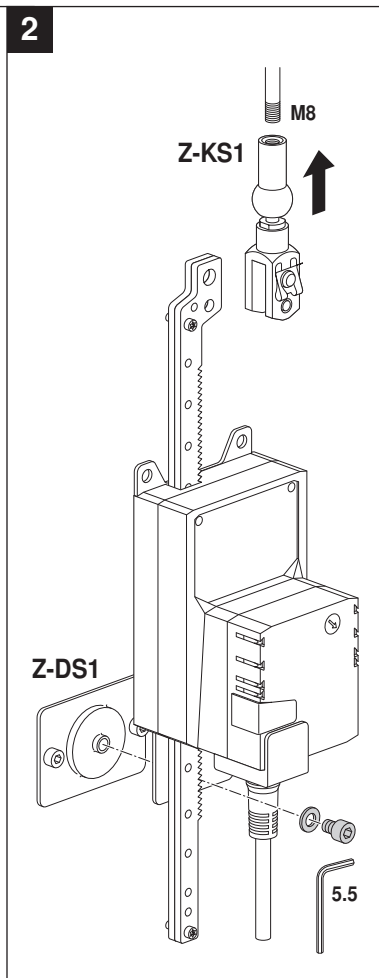
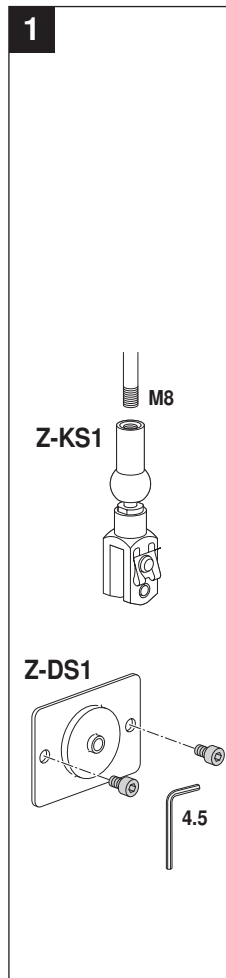
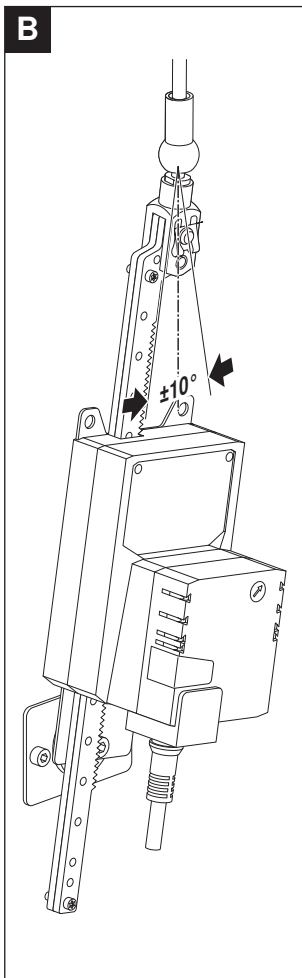
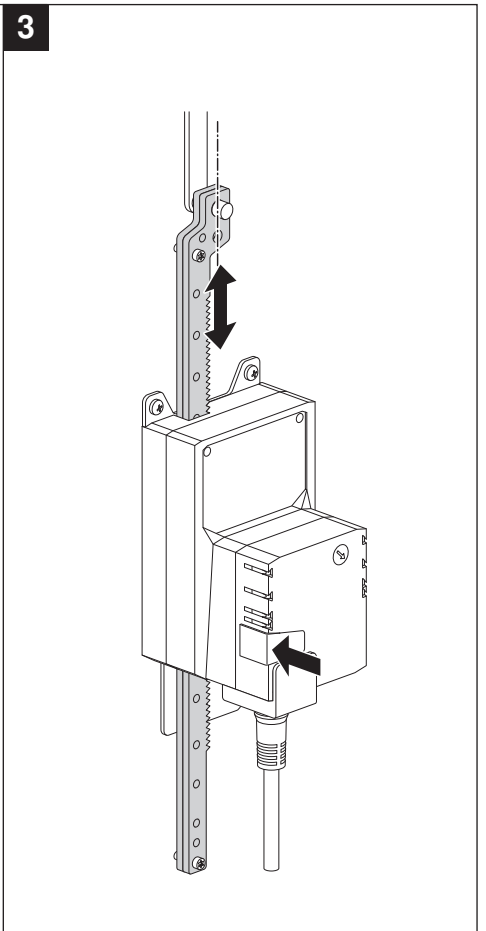
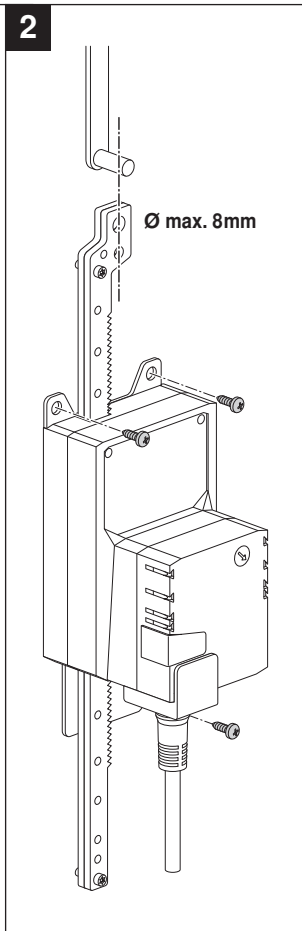
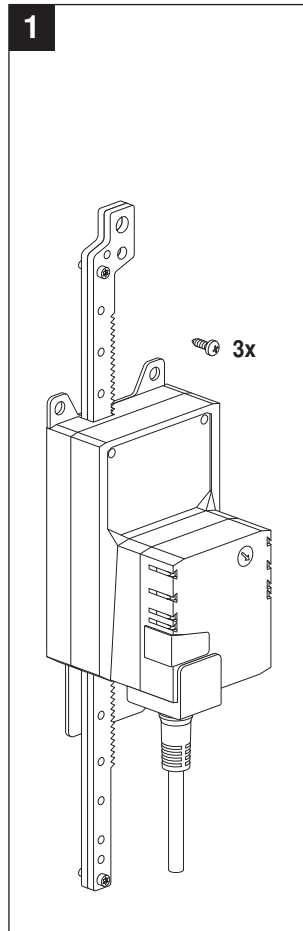
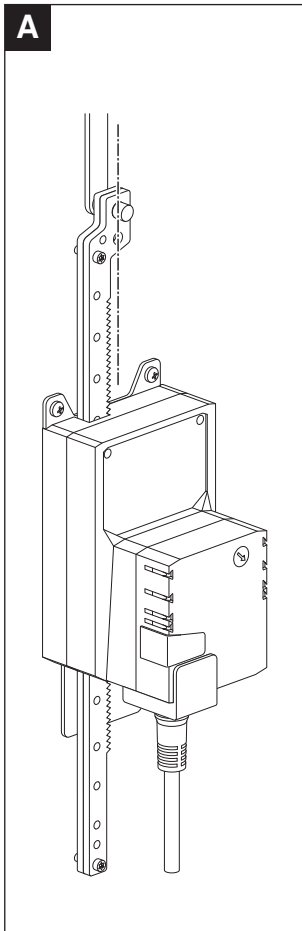

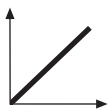
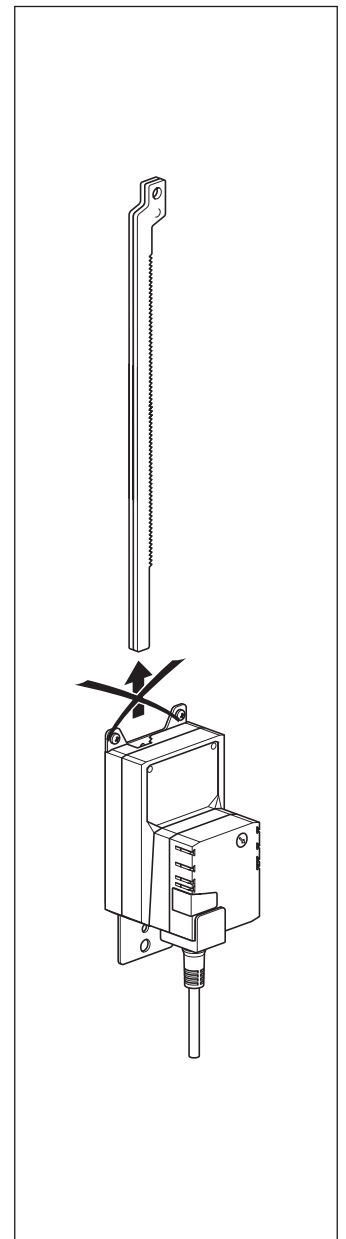
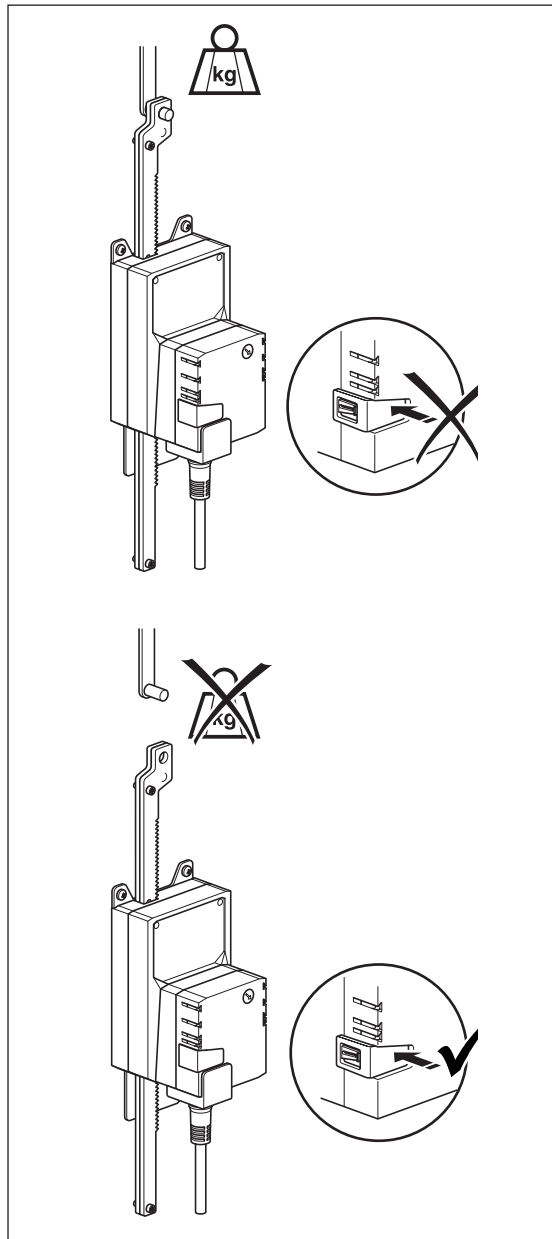

AC 24 V / DC 24 V

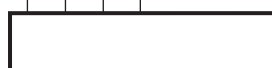
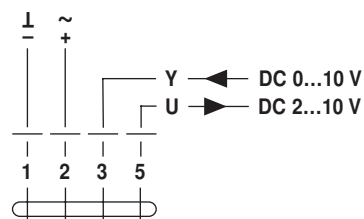

SH24A-SR..

AC 230 V

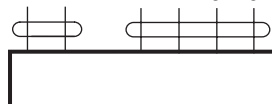
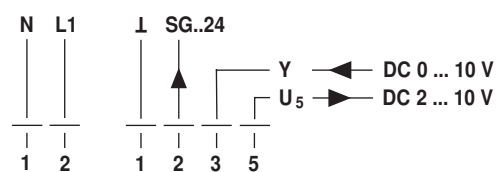

SH230ASR..

## Safety notes



- The actuator is not allowed to be used outside the specified field of application, especially in aircraft or in any other airborne means of transport.
- It may only be installed by suitably trained personnel. Any legal regulations or regulations issued by authorities must be observed during assembly.
- The device may only be opened at the manufacturer's site. It does not contain any parts that can be replaced or repaired by the user.
- The rotary supports and coupling pieces available as accessories must always be used if lateral forces are likely. In addition, the actuator must not be tightly bolted to the application. It must remain movable via the rotary support (refer to «Assembly notes»).
- If the linear actuator is exposed to severely contaminated atmosphere, appropriate precautions must be taken on the system side. Excessive deposits of dust, soot etc. can prevent the gear rack from being extended and retracted correctly.
- If not installed horizontally, the gear disengagement pushbutton may only be actuated when there is no pressure on the gear rod.
- To calculate the actuating force required for air dampers and slide valves, the specifications supplied by the damper manufacturers concerning the surface, cross section, design, installation site and the air flow conditions must be observed.
- If a rotary support and/or coupling piece is used, losses in the actuation force losses are to be expected.
- The device contains electrical and electronic components and is not allowed to be disposed of as household refuse. All locally valid regulations and requirements must be observed.

## Product features

|                                    |   |
|------------------------------------|---|
| <b>Mode of operation</b>           | The actuator is controlled with a standard modulating signal of DC 0 ... 10 V and moves to the position defined by the control signal. The measuring voltage U serves for the electrical display of the damper position 0 ... 100% and as slave control signal for other actuators. |
| <b>Manual override</b>             | Manual override with push-button possible (the gear is disengaged for as long as the button is pressed or remains locked).  |
| <b>High functional reliability</b> | The actuator is overload-proof, requires no limit switches and automatically stops when the end stop is reached.  |

## Accessories

|                               | Description                                       | Data sheet     |
|-------------------------------|---|----------------|
| <b>Electrical accessories</b> | Positioner SGA24, SGF24 and SGE24                 | T2 - SG..24    |
|                               | Range controller SBG24                            | T2 - SBG24     |
|                               | Digital position indication ZAD24                 | T2 - ZAD24     |
| <b>Mechanical accessories</b> | Rotary support to compensate lateral forces Z-DS1 | T2 - Z-SH..A.. |
|                               | Coupling piece Z-KS1                              | T2 - Z-SH..A.. |
|                               | Mechanical limiter set Z-AS1                      | T2 - Z-SH..A.. |

## Electrical installation

### Wiring diagram

#### Notes

- Connect via safety isolating transformer.
- Other actuators can be connected in parallel. Please note the performance data!

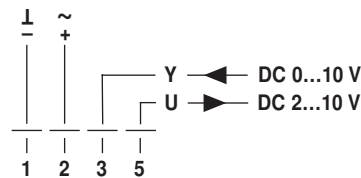

### Direction of stroke



### Cable colours:

- 1 = black
- 2 = red
- 3 = white
- 5 = orange

## Dimensions [mm]

## Dimensional drawings

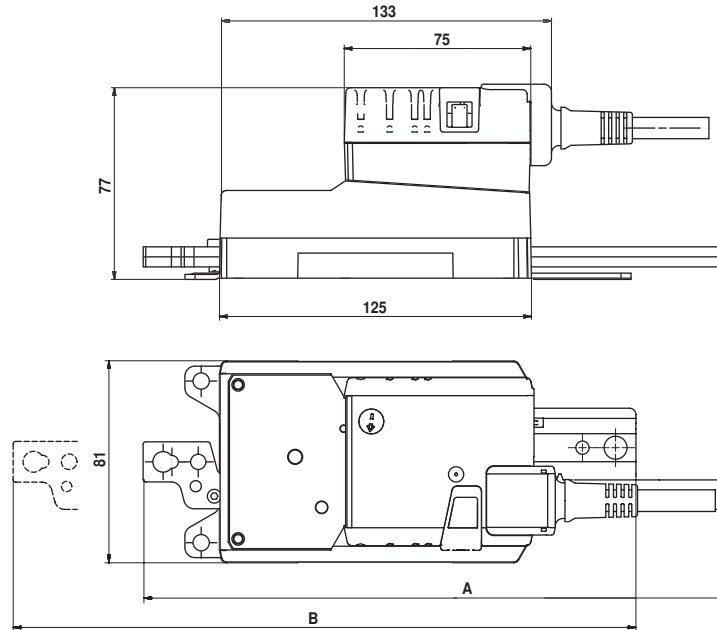

| Type        | Max. Stroke | A     | B     |
|-------------|-------------|-------|-------|
| SH24A-SR100 | 100         | 233.5 | 294.7 |
| SH24A-SR200 | 200         | 333.5 | 394.7 |

## Assembly notes

**Application without transverse forces**

The linear actuator is screwed directly to the housing at three points. Afterwards, the head of the gear rod is fastened to the moving part of the ventilation application (e.g. damper or slide valve).

**Application with transverse forces**

The coupling piece with the internal thread (Z-KS1) is connected to the head of the gear rod. The rotary support (Z-DS1) is screwed to the ventilation application. Afterwards, the linear actuator is screwed to the previously mounted rotary support with the enclosed screw. Afterwards, the coupling piece, which is mounted to the head of the gear rod, is attached to the moving part of the ventilation application (e.g. damper or slide valve). The transverse forces can be compensated for to a certain limit with the rotary support and/or coupling piece. The maximum permissible swivel angle of the rotary support and coupling piece is  $10^\circ$ , laterally and upwards.

**Caution**

If a rotary support and/or coupling piece is used, losses in the actuation force losses are to be expected.

**Stroke limitation**

If the stroke limitations are used on the gear rod, the mechanical working range can be exploited from an extension length of 20 mm.